



USER MANUAL

# the Ruby

JUICE EXTRACTOR



PLEASE READ THIS MANUAL BEFORE OPERATING YOUR JUICER.



# the Ruby

JUICE EXTRACTOR

## ASSEMBLY & CARE :

Please read through this user manual carefully before operating your new juicer.

Congratulations on purchasing the finest commercial grade centrifugal juicer available. If looked after, the **Ruby 2000** will provide you with customer satisfaction and good returns for years to come. It is therefore imperative that you familiarize yourself and your staff with the operations of this juicer for safe and trouble free juicing.

We stand by our product therefore we are offering a 1 year parts 3 months labour manufactures warranty. These instructions must be followed and the juicer must be used correctly. Maintenance must be carried out only by an authorized technician. Failure to comply will result in the voidance of warranty.

## INSTRUCTIONS :

Follow these instructions for safe, trouble free juicing.

**STEP 1.** Upon unpacking your juicer perform an initial inspection. Make sure that the juicer is free of damage that may have occurred during transport, and that all parts have been supplied.

Your box should contain the following items;

- 1 x Ruby 2000 juicer
- 1 x Exhaust Tube (111)
- 1 x 7/8 combination spanner/wrench (020)
- 1 x Pusher / Plunger (108)
- Envelope containing Users Manual and Warranty Card

**STEP 2.** Fill in the warranty card and return to our office within 7 days of purchase.

**STEP 3.** It is now time to look for a place to set up your juicer.

- We recommend a working area of approximately 20"x20" inches or 500mm x 500mm.

• You also require a 110V, 15amp or 220V, 10amp power supply. (depending on country).

• The Ruby 2000 has 8 positions for the juice spout and

2 for the exhaust tube, making it suitable for most locations.

**STEP 4.** Once you have found a suitable location for your juicer remove the top cover. You should see the 7/8 locking nut that holds the cutting blade and strainer in place. Loosen this with your wrench removing it along with the strainer, blade and collection pan. Locate the juice spout in the hole that best suits your workspace. Replace the strainer making sure it locks into position over the 2 pins. Replace the blade, turning it till it locks into place. Replace the 7/8 nut, tightening it firmly with your wrench.

**STEP 5.** Replace the lid and fasten the lock latches on each side. These latches are adjustable. To tighten the latches turn the hooks clockwise and to loosen them do the opposite. Do not over tighten the latches, this will stretch or brake them.

**STEP 6.** Plug in your juicer, making sure step 4 has been completed and the juicer is switched off. You may now turn on the juicer. Your juicer should run smoothly.

# the Ruby

Juice Extractor

## PARTS & ASSEMBLY:

<b>A.</b>	Plunger/Pusher	(108)
<b>B.</b>	Top Cover	(100)
<b>C.</b>	7/8 Nut	(000)
<b>D.</b>	Cutter Blade	(110)
<b>E.</b>	Basket/Strainer	(101)
<b>F.</b>	Exhaust Pins	(000)
<b>G.</b>	Tube/Exhaust	(111)
<b>H.</b>	Pan Collector	(102)
<b>I.</b>	Frame	(103)
<b>J.</b>	Lock Latches	(001)
<b>K.</b>	Shroud	(104)
<b>L.</b>	Drive Plate	(105)
<b>M.</b>	Grub/Set screw	(003)
<b>N.</b>	Motor	(004)
	60Hz - 117V / 50Hz - 220V	
<b>O.</b>	Base	(106)
<b>P.</b>	Strain Relief	(009)
<b>Q.</b>	Switch	(100)
	115-117 Vac / 220, 50Hz	
<b>R.</b>	Spacers	(107)
<b>S.</b>	Rubber Feet	(010)
<b>T.</b>	Spanner/Wrench	(012)

NOTE: Those parts indicated as L, M and N can not be replaced or adjusted except at the factory or by ringing the service department for more information.

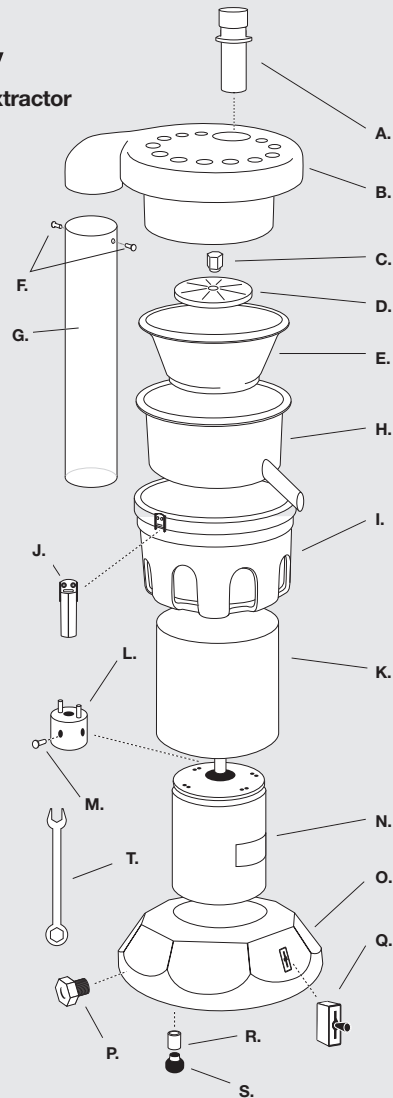

## CLEANING INSTRUCTIONS:

Because fruits and vegetables contain natural substances that will build up and stain your filter if left unclean, it is important that you follow this set of cleaning instructions.

**STEP 1.** Find a suitable container that you can soak your filter in. It will be a good idea if you obtain one solely for this purpose. Container size about 13" x 33cm in diameter and 9"/23cm deep.

**STEP 2.** In about 1 Gallon/4 Liters of hot water dissolve 250grams (1 cup) of dishwashing detergent such as Cascade or other specified by supplier.

**STEP 3.** Rinse your filter under a stream of water removing as much of the pulp stuck to it as possible. Place the filter directly into the solution. It is important that you do not scrub or brush the filter with any abrasive cleaning aids. Allow it to soak over night.

**STEP 4.** In the morning thoroughly rinse

the filter.

**STEP 5.** Follow these instructions after each day of business to avoid build up on your filter.

**Note you may also clean the blade, nut and collection pan in this solution to remove build up and staining.**

### POINTS TO CONSIDER.

- \* Do not leave your filter in an area where it can be damaged.
- \* Do not wash it along with your pots, pans or other cooking utensils. This can often damage your filter.
- \* Do not scrub or brush the filter with any abrasive cleaning aids
- \* If your filter is not cleaned and

maintained your juicer will not function properly.

\* If during the day you are stopping to empty pulp from within the filter frequently, your cleaning procedures must be reviewed. If you experience continuous clogging contact an authorized technician for service.

\* Do not leave water or juice on the top of the motor hub. Over a period of time this liquid can make its way into the bearings damaging them.

## MAINTENANCE:

\* You should have your machine serviced at least once a year. Like most things if you have your juicer serviced regularly, expensive repairs may be avoided.

\* Your blade over time will wear dull. The blade can be re-sharpened for better yield.

\* Your juicer should only be serviced by an authorized technician.

\* Do not alter your juicer in any way or form. This will void any warranty.

\* Bearings do not require lubrication.

## TROUBLE SHOOTING TABLE:

SYMPTOM	POSSIBLE CAUSE	WHAT TO DO
JUICER WON'T START	No electricity	Check your power point to see if it is working. Check that the cord is not broken
JUICER STARTS SLOWLY	Improper electric current	Make sure there is a sufficient current supply.
PULP IS NOT BEING EXPELLED	Clogged holes in basket	Make sure that you follow the cleaning instructions specified in this manual.
EXCESSIVE VIBRATION	7/8 nut has become loose Filter clogged	Check that the central locking nut is not missing or loose. Tighten with wrench supplied.
MOTOR STALLS	Overloading of feed	Reduce pressure on the pusher as you feed the product into your machine.
LOOSE COVER	Side latches have not been adjusted correctly.	You can adjust your side latches by rotating the hooks either clockwise to tighten or counter-clockwise to loosen. Do not over tighten the latches this may stretch or damage them.

## SERVING SUGGESTIONS:

Over the past 30 years this juicer has been developed to extract juice from almost all types of fruits and vegetables. The unique design of the cutter blade and the large strainer basket insures a maximum amount of juice from your product.

To assist you to capitalize in this market here are a few suggestions given to us by successful operators;

**ORANGE:** PINEAPPLE  
ROCKMELON  
CARROTS  
APPLE  
MANGO  
PAW PAW

**APPLE:** CARROT  
HONEYDEW  
PINEAPPLE  
LEMON  
(Ginger as additive)

**CARROT:** CELERY  
TOTO  
CUCUMBER  
GINGER  
BEATROOT

**WATERMELON:** STRAWBERRY  
MINT  
ORANGE

**PINEAPPLE:** MINT  
APPLE, LEMON, GINGER  
GINGER

**BEFORE CONTACTING OUR OFFICE REFER TO  
YOUR USER MANUAL AND CHECK**

- your appliance is correctly installed
- you are familiar with its normal operation
- you have read the problems solving pages at the back of the book

**IF YOU NEED SERVICE OR ASSISTANCE PLEASE CONTACT US AT**

**RUBY MFG. INC.**

9853 Alpaca Street | SOUTH EL MONTE CA. 91733 | tel: +626 443 1171 | fax: +626 443 0028  
[www.rubymfg.com](http://www.rubymfg.com) | [info@rubymfg.com](mailto:info@rubymfg.com)

**LIMITED FACTORY WARRANTY**

Ruby MFG. INC., warrants the workmanship and all parts against defects for a period of 1 year and 3 months labour from the date of original purchase for use. This warranty shall be effective only if the registration card is fully completed and mailed to Ruby MFG. INC. Warranty only applied to original purchaser and is not transferable.

This warranty is null and void if the unit and/or its components therein have been damaged or tampered with by improper handling, use or unauthorised repair. In all cases of damage during transport, for repair, a claim must be filled with the shipping carrier by the purchaser. In all events the manufacturer agrees to repair or replace defective parts but never to exceed the purchase price paid. As this is limited, Ruby MFG. INC. liability for cosequential and incidental damages is expressly disclaimed and shall not exceed the purchase price paid.

[www.rubymfg.com](http://www.rubymfg.com) | [info@rubymfg.com](mailto:info@rubymfg.com)

**RUBY MFG INC.** | 9853 Alpaca Street | SOUTH EL MONTE CALIFORNIA 91733 | tel: +626 443 1171 | fax: +626 443 0028